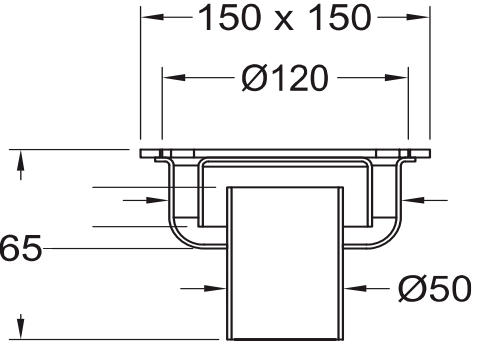

PHOTO	DESIGNATION
	SIPHON INOX ZENITH 15X15 SAR916
	
	CODE ARTICLE
1141021802	

CARACTERISTIQUES

MATERIAUX	ACIER INOXYDABLE
FONCTION	DISPOSITIF DESTINE A L'EVACUATION DES EAUX USEES ET LA RETENTION DES ODEURS
CARACTERISTIQUES TECHNIQUES	EVACUATION: DN50 A SORTIE VERTICALE GARDE D'EAU: 30 MM GRILLE: MICROBILLEE, POLIE RESEISTANCE: 3 KN SELON LA NORME EN-NF1253-2 COMPOSITION: UN BOITIER DE SIPHON, FINITION POLIE, UNE GRILLE-CLOCHE APPLICATION: GARAGE, TOIT, DOUCHE, BUANDERIE, INDUSTRIE...
DIMENSIONS (EN MM)	150 x 150 x 65
EMBALLAGE	EMBALLAGE A L'UNITE EN BOITE REEMBALLAGE DE 20 UNITES

